

Materials of Construction

Component	Material Specification
Cylinder	Grey Cast Iron EN-GJL-200 / EN-JL-1030 (EN1561)
Coverplates	Grey Cast Iron EN-GJL-200 / EN-JL-1030 (EN1561)
Rotor / Shaft	S.G. Iron EN-GJS-400-15 / EN-JS-1030 (EN1563)
Spacing Rings	Grey Cast Iron EN-GJL-200 / EN-JL-1030 (EN1561)
Foot	Mild Steel Black FE430A (EN10025)
Blades	Non-Asbestos Resin Bonded Fabric
Ball Bearing	Single row, deep groove ball with metal cage Clearance – Normal, 2 seals
Lip Seals	Steel cased, Viton
O-Rings	Viton
Cylinder	Grey Cast Iron EN-GJL-200 / EN-JL-1030 (EN1561)

Performance

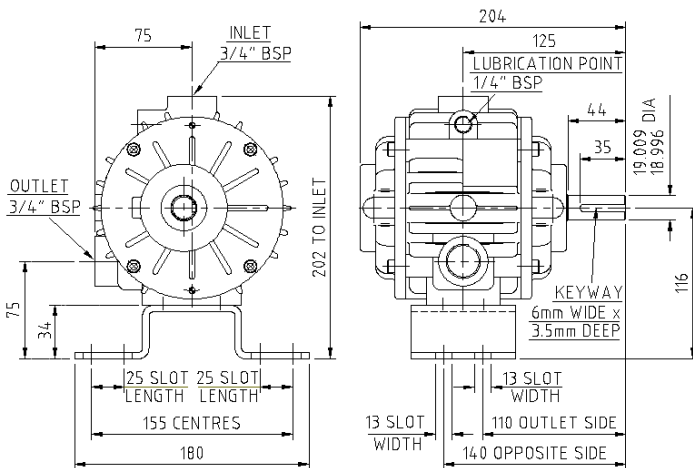
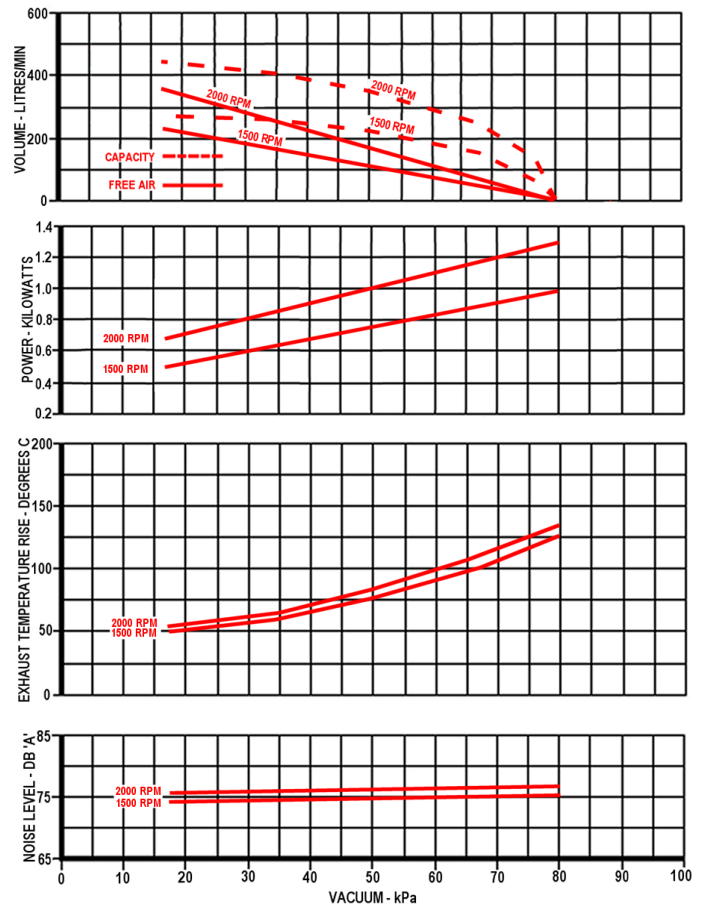

SPEED

Maximum Speed	-	2400	RPM
Minimum Speed	-	1000	RPM

TEMPERATURE

Max. Inlet Temperature	-	40	°C
------------------------	---	----	----

INERTIA

Moment Of Inertia	-	0.001	Kgm ²
-------------------	---	-------	------------------

WEIGHT

Approximate Weight	-	13	kg
--------------------	---	----	----

LUBRICATION

Single feed oiler to cylinder for blade lubrication
Bearings greased for life using SHELL ALBIDA RA grease.
Blades lubricated using SHELL RIMULA X 15W/40 oil.

BEARING ARRANGEMENT

Ball bearing at both ends giving approximate life values for drive end and rear end of 200000 hours.